

360°
inspection and quality control

J PRISMA
P A R M A I T A L Y



checkweigher
09T3





discover all the details on our web-site!



Technical Specifications

Weighing range	up to 10000 g
Display division	from 0,1 g
Linear speed	up to 50 m/min
Throughput	up to 100 ppm
Accuracy*	from ± 1 g
Pneumatic supply	0,6 Mpa
Air consumption (for ejection)	5 NI
Power supply	230V 50/60Hz single phase
Power consumption	800 W
Mirror finishing of metal parts	Stainless Steel IP65
Climatic environment	from 5°C up to +40°C non-condensing (closed)

*depending on the weight, dimensions and type of product

Electronics

T3



- Digital electronics with PC Mainboard mini-ITX
- 10,4" TFT color display with touch screen panel
- Windows 10 IoT operating system
- 200 storable product programs

D3



- Digital electronics with alphanumeric graphic display
- 100 storable product programs

Equipment

- Electronic self-calibration device
- Mobile average function
- Conformity with standards ISO - FDA - HACCP - GMP - CE
- 2 RS232 serial ports
- 3 levels password access protection
- Production data management in conformity with the standards in force

Optional

- Ejection systems
- Alarms notification
- Reject management systems
- USB interface
- Stainless steel rejection bin
- Ethernet interface for Industry 4.0 compliance
- Wind-prevention tunnel
- Products programs memory expansion
- 24-columns panel printer
- Feed-back function
- Special conveyors
- FAT/SAT, IQ/OQ validations, CFR21 part 11
- Quick-disassembly conveyors (320 mm belts)
- MID Certification

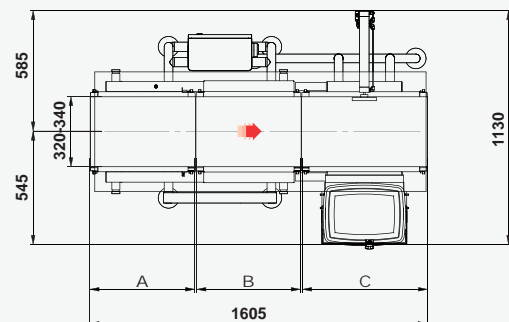
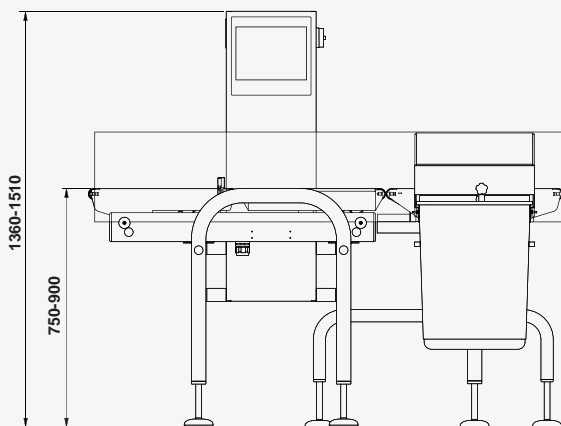

Plates configuration		
Infeed A	Weighing B	Outfeed C
500	500	600
400	600	600



The manufacturer reserves the right to change the product specifications without notice. The image and the drawing are indicative of one of the possible configurations of the machine.