

SEMI AUTO TAMPER EVIDENT BAND SEALER

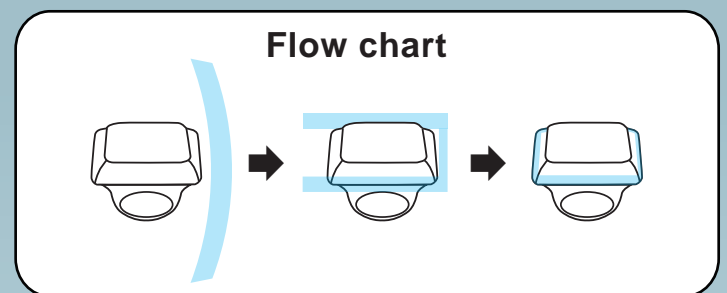

HA-BA150SA-BE

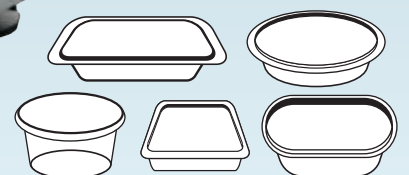

The form of the package

SPECIFICATION

Model Number	UNIT	HA-BA150SA-BE	Remarks
Power		1Φ / 220V / 50/60Hz	
Motor		AC180W X1 60X1	
Air Pressure	kg/cm ²	5.5 (80psi)	
Heater	W	0.7KW X 6 0.2KW X 1 90W X 8	Changeable by product or working speed
Packing Speed(Max.)	(BPM)	Max.15	Varied Speed by packaging size or weight
Applicable Material		PET / PLA	PVC film is not recommended, because it will create toxic air to damage machine.
Film Width	mm	38 ~ 150	Can be changed by packaging requirement.
Film Thickness	mm	0.025 ~ 0.07	
Printed Film		Only available for random surface print	
Packaging width	mm	80 ~ 250	
Packaging height	mm	30 ~ 150	The gap between film bottom edge to conveyor belt must be 5mm at least.
Packaging weight (Min.)	g	Min.250	
The form of the package		Light or low container is not recommended.	

Features

1. Economical film using can save cost & reduce wastage.
2. Stainless steel frame can be durable with longer working life.
3. To pack multiple size containers without needing adjust machine.
4. Compact design can be moved easily to fit any working space.

- Our packaging specialists will provide you the most efficient and energy-saving packaging system for your products.
 - All specifications, design and characteristics shown on this catalogue are subject to change without prior notice.
- ※ ALL MACHINES ARE LIABILITY INSURED.

MACHINE DIAGRAM

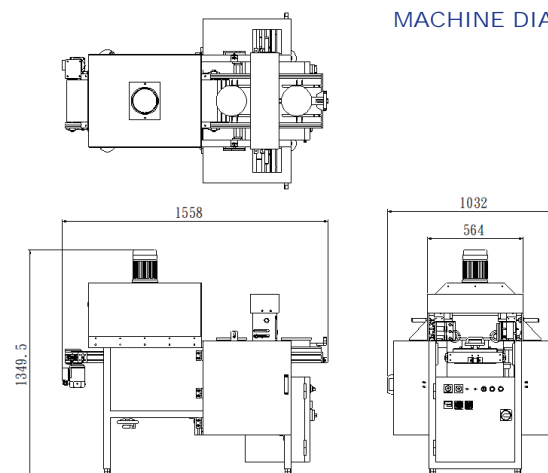

Halco Packaging ApS
 Viborgvej 97A
 DK-7400 Herning
 T: +45 75 10 27 44
 E: salg@halco.dk