

# FW SERIES

FW300E - FW400E - FW500E  
ENTRY-LEVEL MODELS

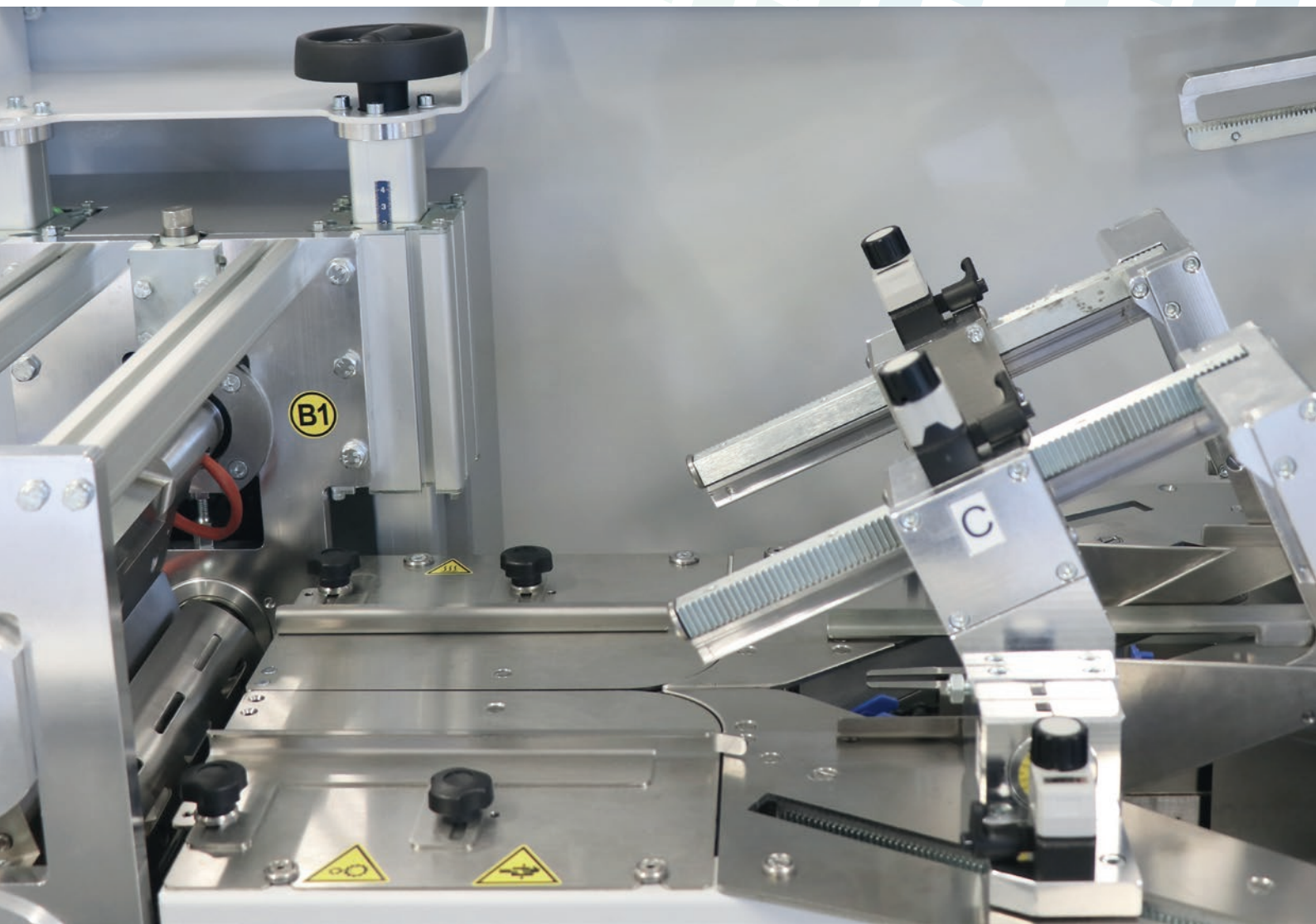

New models of flow pack machines with  
rotary sealing system and upper reel



## FW300E - FW400E - FW500E

The new FW series packs a wide range of products with irregular shapes and small dimensions that arrive at the machine either loose (single doses) or previously grouped (multipack). The products are placed in packages made up of simple or coupled flexible material with a maximum output of 200 products/minute (based on the selected model). The film sealing & folding systems, combined with the dynamic and adjustable conformer, make process regulation on the FW models versatile and fast.



## ADVANTAGES AND FEATURES

- Sealing system with rotary bar
- Infeed conveyor with adjustable guides and easily removable interlocking vanes
- Sliding surfaces of the products in AISI304
- Longitudinal sealing consisting of 2 pairs of drive wheels: the first pair drags the film and the second does the sealing
- Opening of the longitudinal sealing wheels: manual (FW300E), pneumatic (FW400E - FW500E)
- Upper reel holder with mechanical clutch
- Reel holder shaft: manual closing (FW300E), pneumatic expansion (FW400E - FW500E)
- Standard dynamic film conformer with position indicator with numerical display
- Adjustment of cross bar height by handwheel
- Motorized outfeed conveyor adjustable in height by handwheel
- Drawers to collect product waste, under the entire length of the infeed conveyor
- Flxmod® control system equipped with:
  - » 7" full-color touch screen display with PLC user-friendly
  - » IN/OUT control modules for digital, analog inputs/outputs and thermocouple-reading control
- Possibility of scheduling up to 50 different working cycles
- Compliance with CE regulations



## FW300E • 80 products/minute



## FW400E • 100 products/minute



## FW500E • 120 products/minute



- Automatic flow pack machine with rotary sealing FW300E
- Cross sealing bar: 150 mm
- Maximum product height: 60 mm
- Infeed conveyor, longitudinal sealer and outfeed conveyor with independent asynchronous motors controlled by inverters
- Cross sealer with independent brushless motor controlled by driver

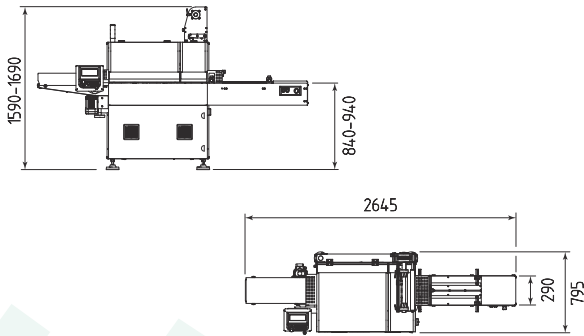

- Automatic flow pack machine with rotary sealing FW400E
- Cross sealing bar: 150 mm
- Maximum product height: 80 mm
- Infeed conveyor, longitudinal sealer and outfeed conveyor with independent asynchronous motors controlled by inverters
- Cross sealer with independent brushless motor controlled by driver

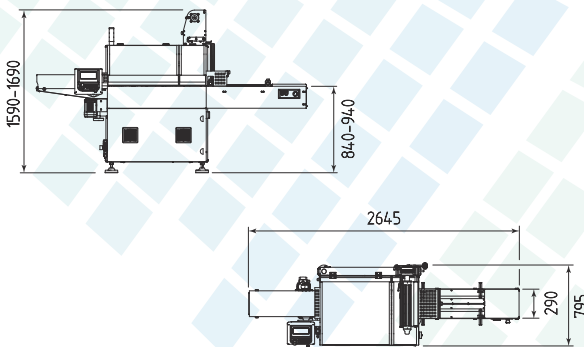

- Automatic flow pack machine with rotary sealing FW500E
- Cross sealing bar: 250 mm
- Maximum product height: 100 mm
- Infeed conveyor, longitudinal sealer and outfeed conveyor with independent asynchronous motors controlled by inverters
- Cross sealer with independent brushless motor controlled by driver

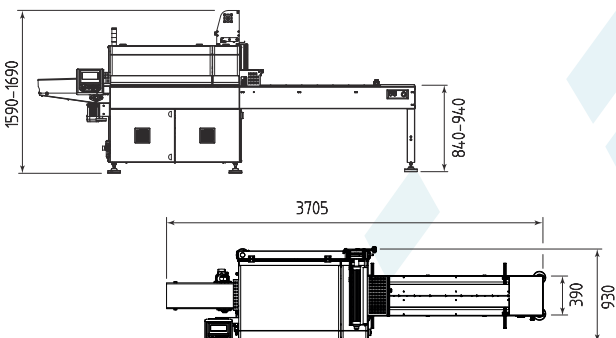

## OPERATION

The product is loaded by hand onto a paddle feed belt. The film is unwound from the reel-holder onto some return rollers and, after passing through the film directing device, it reaches the former unit where special guides arrange it in such a way as to completely wrap the product. A continuously-operating sealer longitudinally seals the two ends of the film at the bottom of the pack, then a rotary-operating cross sealing bar simultaneously seals the tail end of the bag of a product and the head of the next one. During transverse sealing, cutting also occurs, dividing the bagged products. A conveyor belt takes the packaged product out of the machine.

FW300E-FW400E

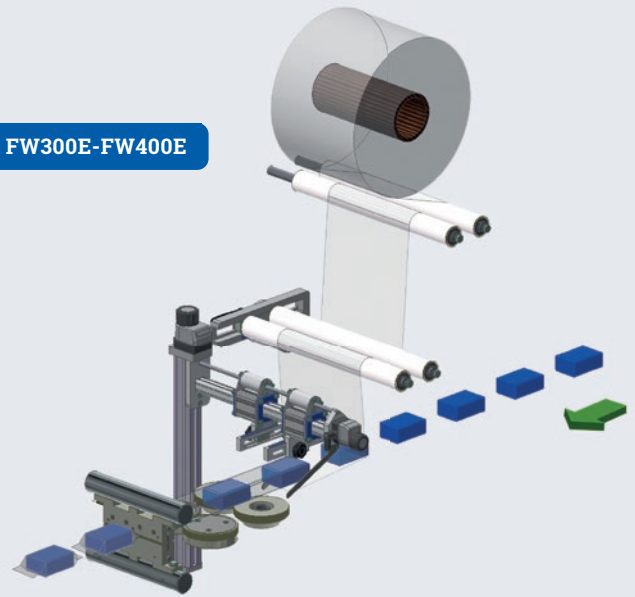

FW500E

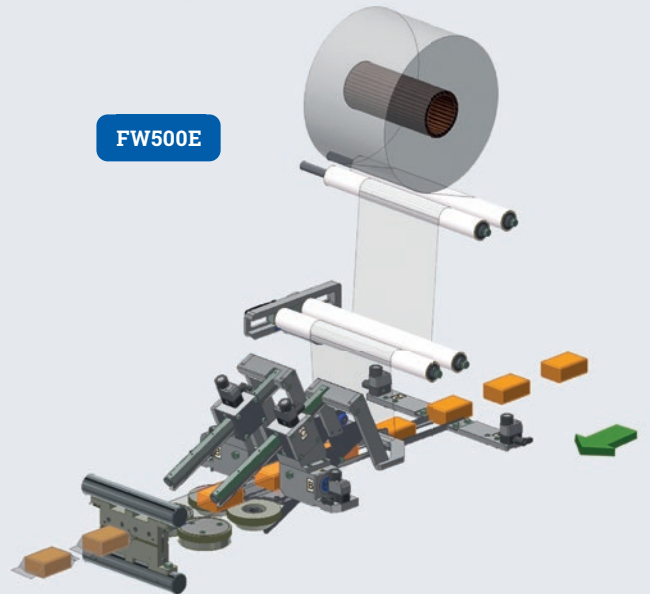

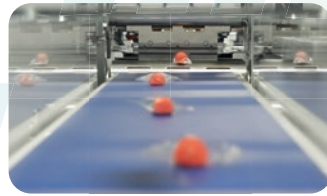
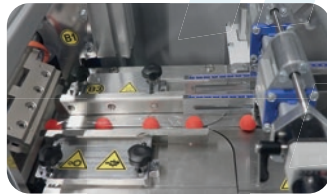
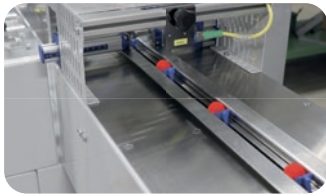

FW300E QR  
Video Code

TECHNICAL SPECIFICATIONS		FW300E •	FW400E •	FW500E •
Power supply	V Hz	220/240 1PH+N+PE 50/60	220/240 1PH+N+PE 50/60	220/240 1PH+N+PE 50/60
Installed power	W	2650	2650	2650
Air pressure	bar	-	6	6
Sealing bar	mm	150	150	250
Maximum product height	mm	60	80	100
Output up to	ppm*	80	100	120
Maximum size film reel	mm	300 - ø 300	400 - ø 300	500 - ø 300
Machine size	mm	2645 x 795 1590 - 1690	2645 x 795 1590 - 1690	3705 x 930 1590 - 1690
Machine net weight	kg	330	330	440

\* ppm - products per minute  
The stated speed can change according to the product size, the pack collation and the type of film used.

• Available also in Stainless steel

The information stated in this brochure can change without notice / The various available accessories will be specified in the offer.

[www.smipack.it](http://www.smipack.it)



**SMIPACK S.p.A.**  
Via Piazzalunga, 30  
I-24015 San Giovanni Bianco (BG)  
Tel.: +39 0345 40.400  
E-mail: [info.smipack@smigroup.net](mailto:info.smipack@smigroup.net)