

# TILBUD på Komplet Pose pakke Linje

## VFFS Machine combined/ 10 heads HA-1040a10



About weighing:

1. Independent discrete plate control for each channel makes the control of the scale more precise and convenient for maintenance.
2. The sampling timing can be adjusted according to various occasions to complete accurate and fast sampling. With a new generation of AD weighing sampling circuit and stepper motor control circuit.
3. With asynchronous material prevention function, better prevent material blocking.
4. It is more convenient to add additional weighing-type level measurement control and center-rotating material distribution related devices

**About packaging machine:**

1. Temperature controller has been increased to three, the front horizontal seal, back horizontal seal and vertical seal are independently controlled for temperature control, which is more accurate and stable.
2. Packing machine is more convenient to add other extra device like fixed number of alarms, shutdown, failure alarm, rejection, shutdown and other functional devices.

## Bucket elevator



### HA-3-5

Consists of elevator, storage silo and feeding vibrator.

Material: 304 Stainless steel

Chain material: 304 stainless steel + POM Plastic

Hopper volume: 1,5 L

Hopper material: PC + Dimpled

Main chain speed: 0,3 m/s

Level part length: 1,44 m

Lifting height: 2,4 m

Max. lifting capacity: 6 m<sup>3</sup>/h

Lifting motor power: 0,75 kw

Feeding power: 300w

Feeder height: 870 mm

Feeder vacuum: 75L



Halco Packaging ApS, Viborgvej 97A, DK-7400 Herning  
(+45) 7510 2744 - sales@halco.dk

# Take away conveyor



## HA-5-1

Body material: 304 Stainless steel

Belt material: PVC

Max. speed: 0.3 m/s

Feed height: 160 mm

Discharge height: 800 mm

Power: 180 W

Voltage: 220v

## Mål på HA-1040a10

Max. film reel:  $\varnothing$  400 mm

Bag length: 230 mm

Bag type: Pillow bag / gusset bag

Max. Speed: 60 bag/min.

Air consumption: 0.5 m<sup>3</sup>/min. 0.6 PA

Power: 4,5 kW

Voltage: 220 v

Package size: (mm): 1550 x 1290 x 2220

Gross weight: 765 kg

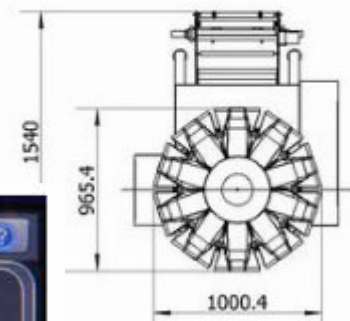
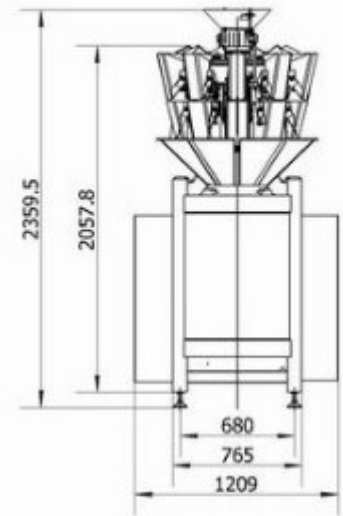

1. Independent discrete plate control for each channel makes the control of the scale more precise and convenient for maintenance.

2. The sampling timing can be adjusted according to various occasions to complete accurate and fast sampling. With a new generation of AD weighing sampling circuit and stepper motor control circuit.

3. With asynchronous material prevention function, better prevent material blocking.

4. It is more convenient to add additional weighing-type level measurement control and center-rotating material distribution related devices

5. Temperature controller has been increased to three, the front horizontal seal, back horizontal seal and vertical seal are independently controlled for temperature control, which is more accurate and stable.

6. Packing machine is more convenient to add other extra device like fixed number of alarms, shutdown, failure alarm, rejection, shutdown and other functional devices.



Material: 304 Stainless steel  
Screen: 10.4 inch touch screen  
Hopper volume: 1,5 L  
Weight Heads Unit: 10  
Weight Heads Layer: Double  
Weight Heads Type: 1 liter single opening  
Max weight: 1 kg  
Weighing accuracy: +- 0,5 – 1,5 g  
Horizontal Seal Power: Cylinder  
Film pulling power: Servo motor  
Film material: Composite film / PE film  
Film thickness: 0.04 - 0.12 mm  
Max. film width: 400 mm  
Bag width: 60-190 mm



Halco Packaging ApS, Viborgvej 97A, DK-7400 Herning  
(+45) 7510 2744 - sales@halco.dk